

FRENCH FITNESS

FF-WMDCCC

FRENCH FITNESS WALL MOUNTED
DUAL CABLE COLUMN COMPONENT

OWNERS & ASSEMBLY MANUAL



FEATURES

- Brand: French Fitness
- Dual 165 lb weight stacks for balanced resistance training
- Twenty-six height adjustment points for precise setup
- Rotating pulleys that allow movement from multiple angles
- Heavy-duty steel frame with smooth welds
- Electrostatic paint finish for long-term surface protection
- Rubber feet for added stability
- Quick adjustment system for efficient session flow
- Wall-mounted design that keeps the footprint compact

TECH SPECS

- Cable Reach: 63"
- Height Adjustment Points: 26
- Dimensions: 39"W x 4.3"D Frame (8.3" w/Cables) x 77.5"H
- Wall Mounting:
 - - Four Mounting Holes
 - - (2) at 15.25" high
 - - (2) at 65.25" high
 - - All spaced 20.5" apart

WARRANTY

- **Lifetime Frame Warranty**
- **10 Years Parts Warranty***
- **1 Year Labor Warranty***

*What is covered? See complete [French Fitness Warranty](#) details.

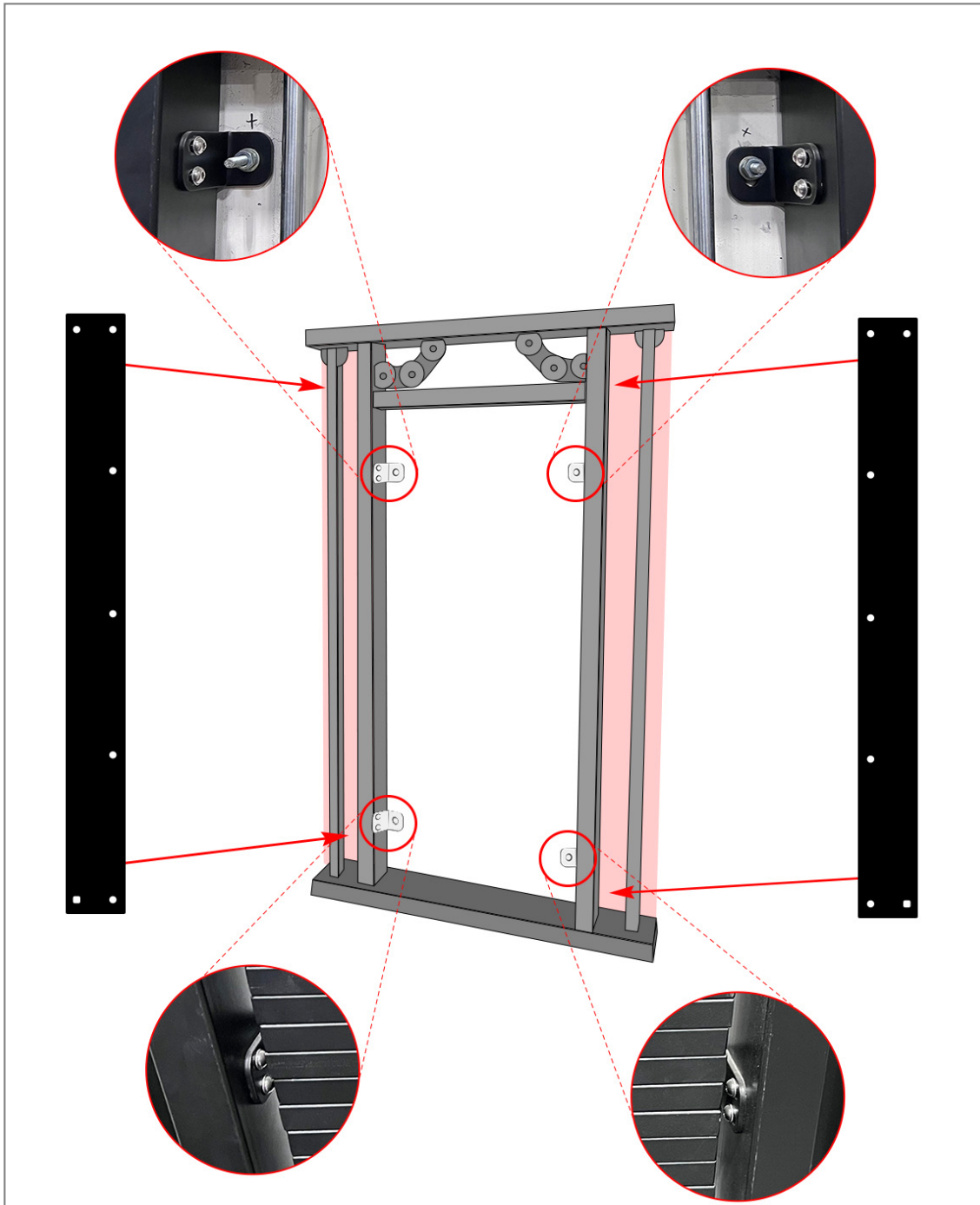

1. Stand the Functional Trainer Upright.
2. Install the metal shrouds at the back of the column, follow the holes where the bolts will go through as shown.
3. Locate the wall mounting holes in the functional trainer. The wall mounting bolts will go through the holes.

Note: Cables and pulleys come pre-routed. This is not shown in the pics.

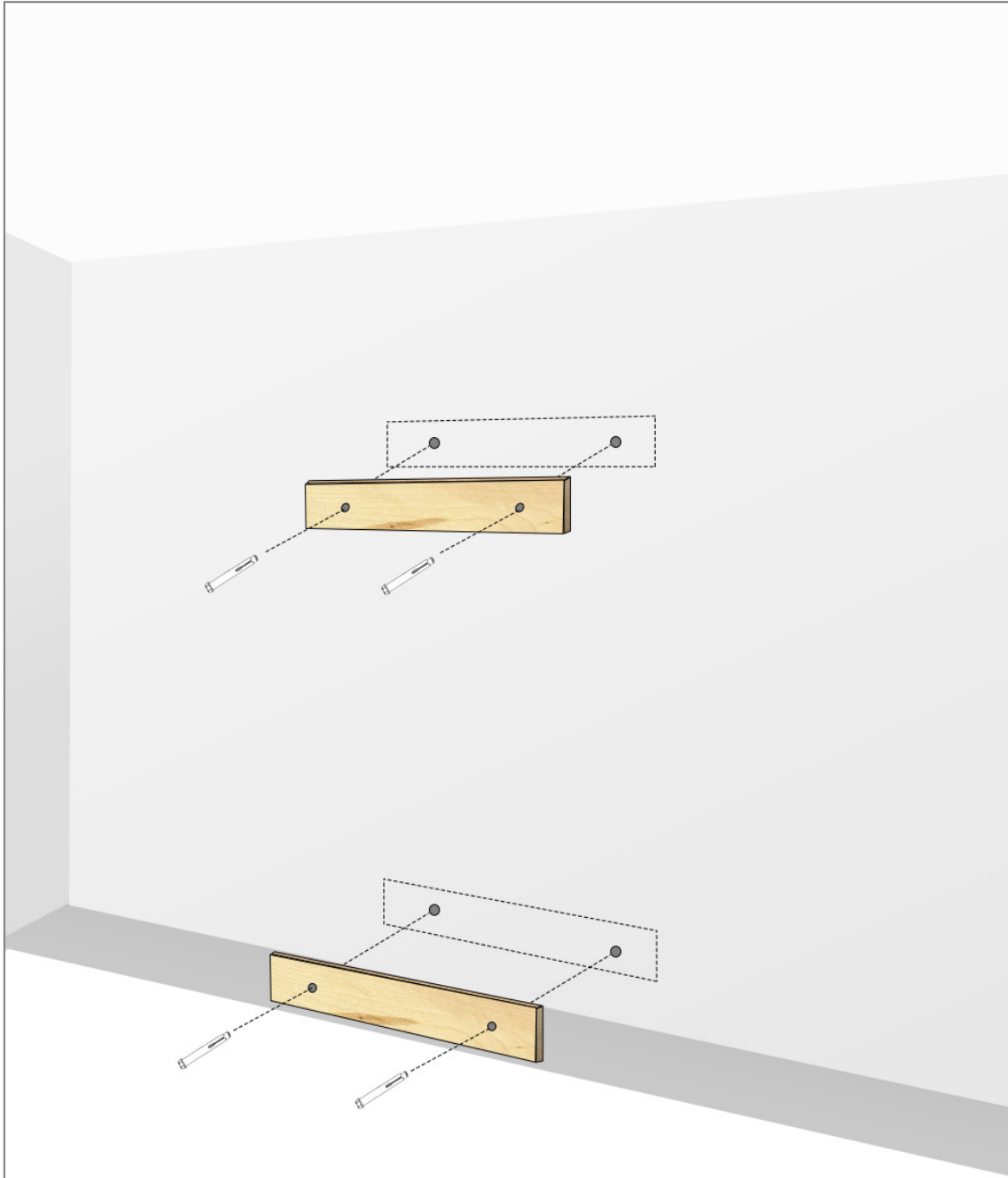

- 4) Locate Concrete or Wooden 2x4 / 4x4 studs in the wall. Mount (2) 2x4's horizontally onto the wall to align with the holes. Mount each into 2 different wooden studs along the wall making at least 6 holes in the wall total

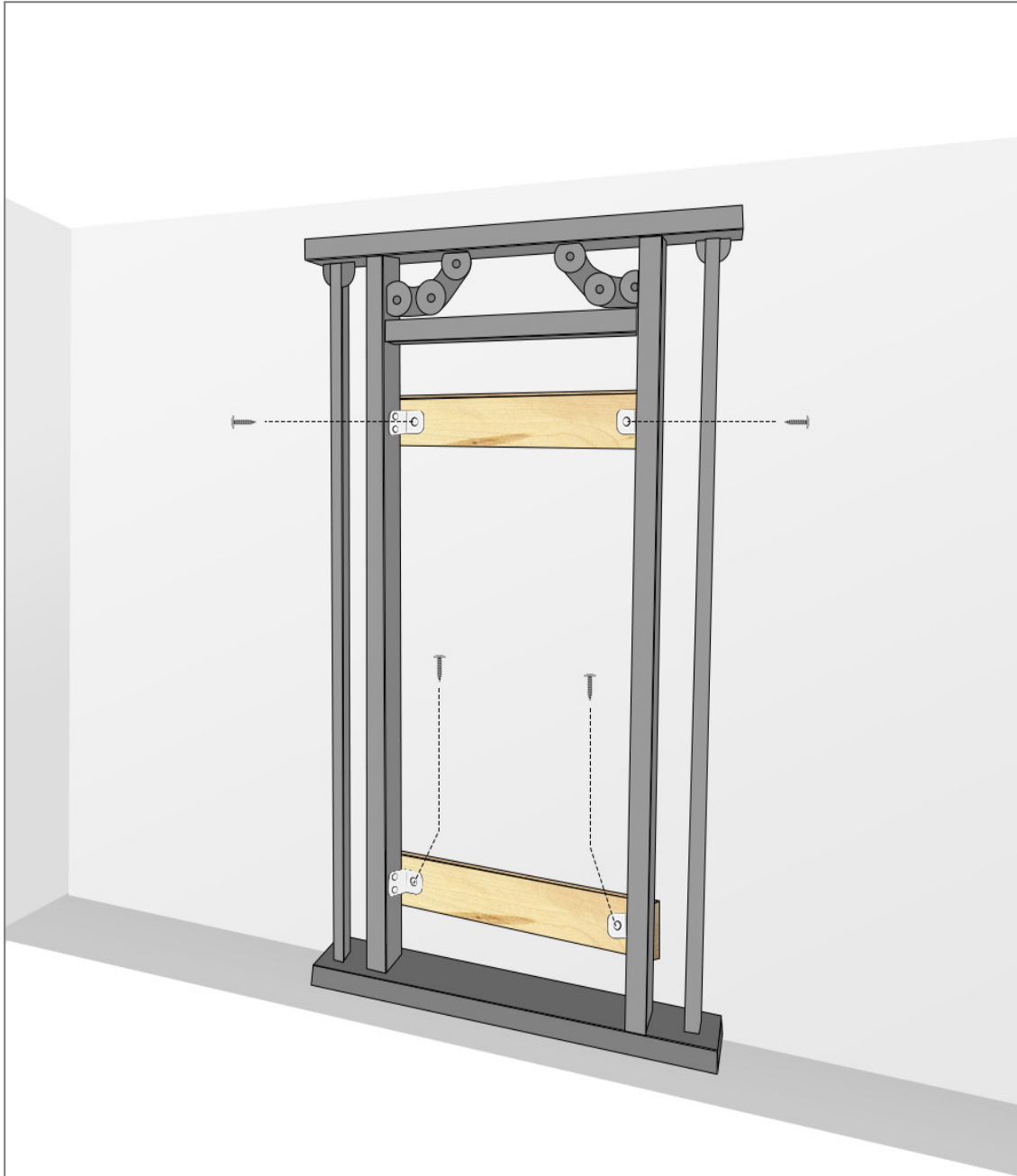

- 5) Mount the 4 included mounting bolts through the 4 back holes on the machine into the 2x4's that have been mounted to your wall

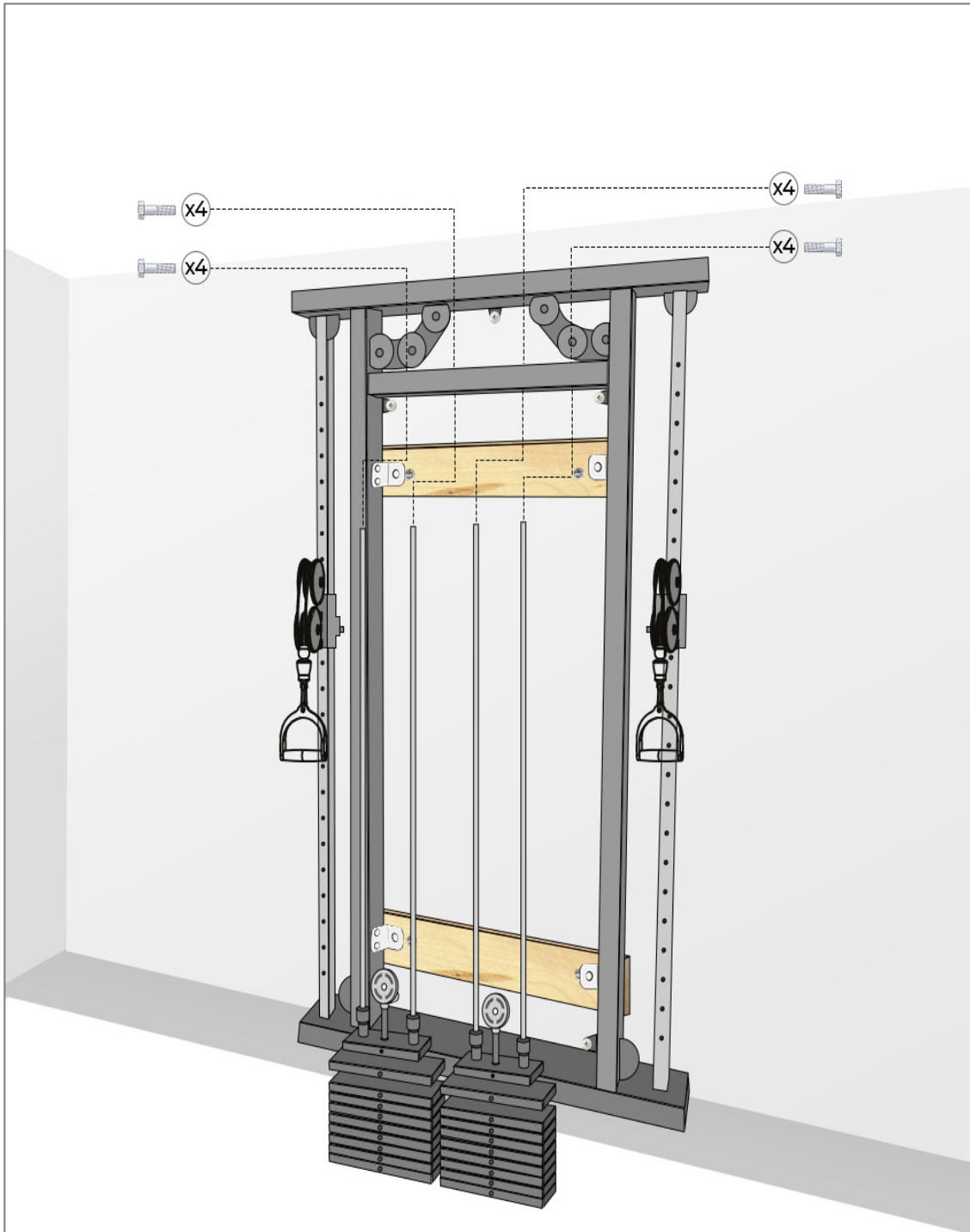

6) Install the weights. The large weights will go in first on each side evenly while the small weight goes in last.

CABLE ROUTING

The blue lines below which represent the route of the cables.

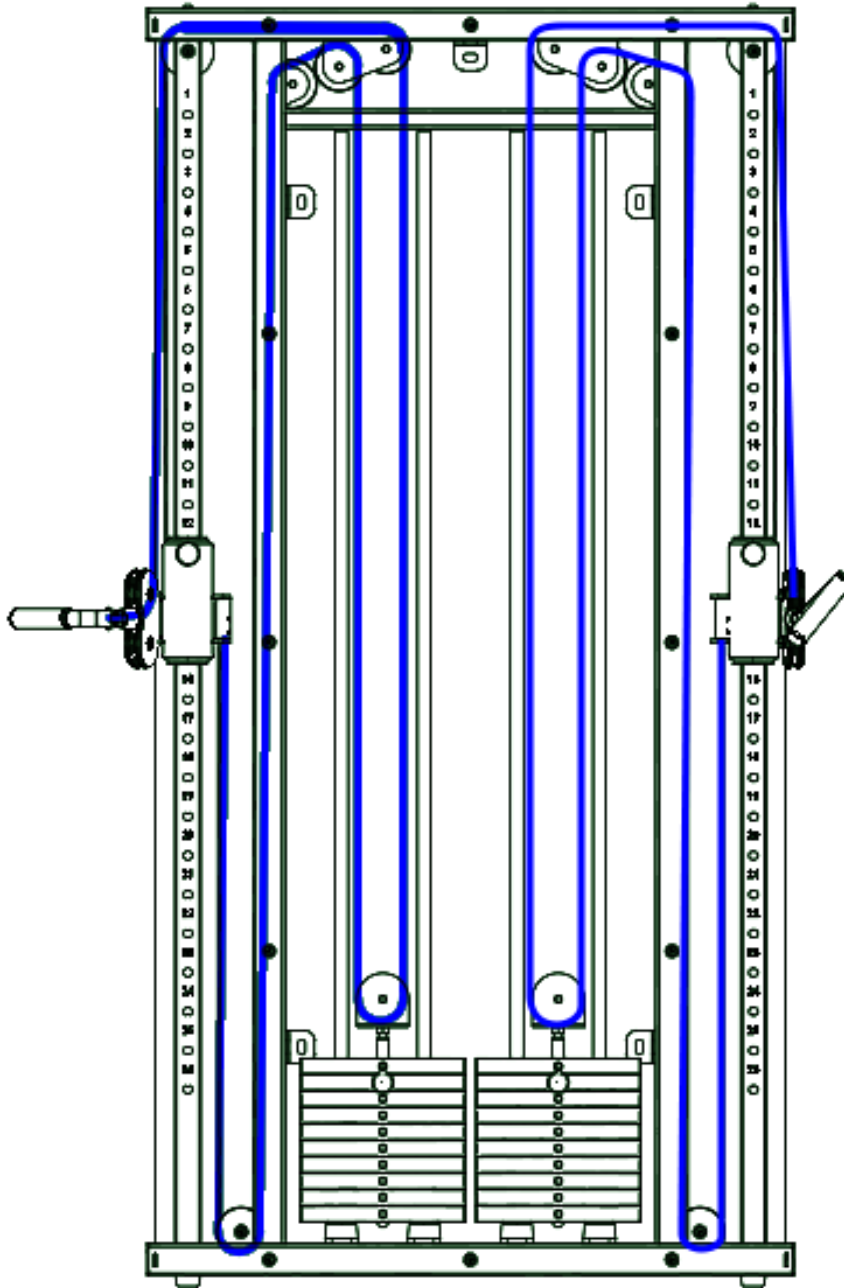

SLIDE (4) SILVER CYLINDERS

Glide the (4) Silver Cylinders w/Set Screws to the top of the guide rods, at a point where the cylinders touch the top of the frame. Once in place, tighten the set screws so they are secure.

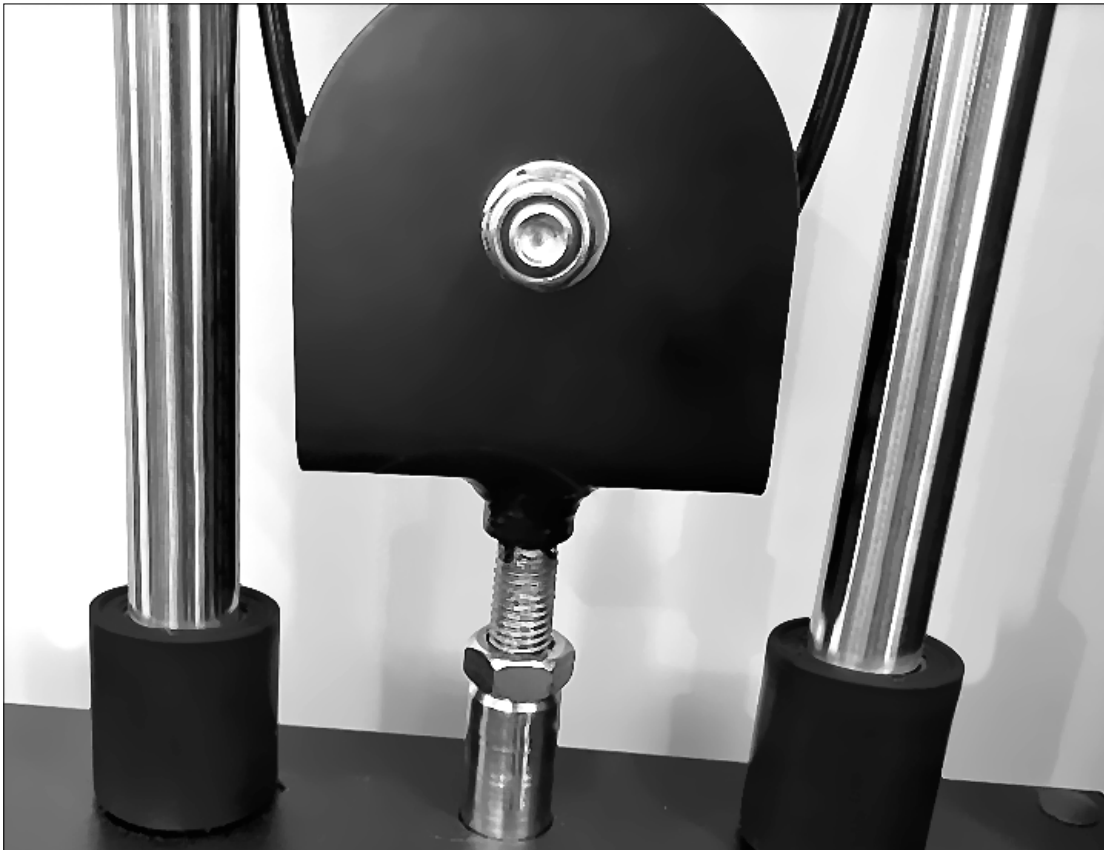
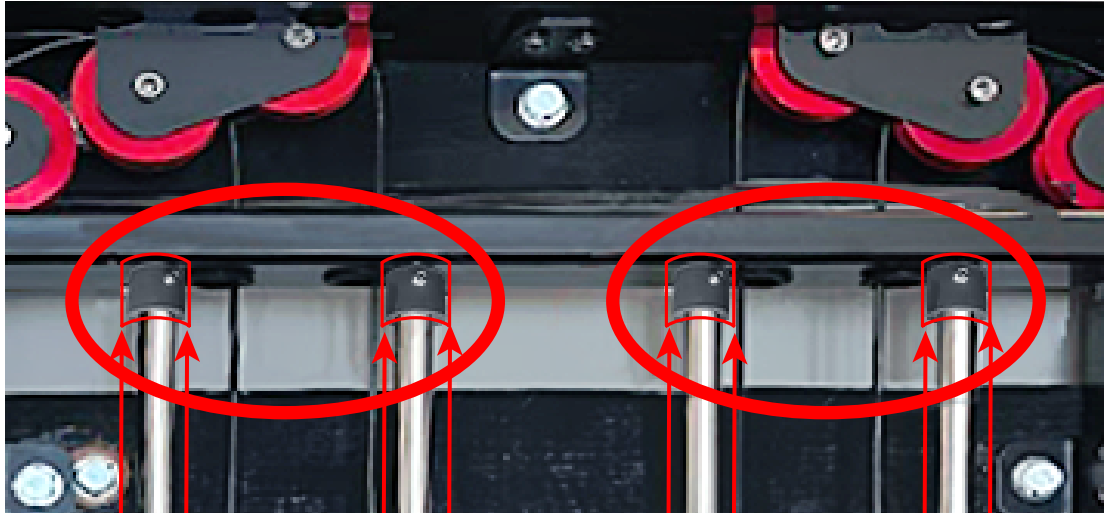

CABLE TENSION ADJUSTMENT

Adjust Cable Tension by adjusting the nut which is shown in the pic below in red. Do this using a wrench on both stacks

You will need to find a point where cable tension is tight, but the top plate does not lift. If cable tension ever loosens or top plate raises, then adjust here.

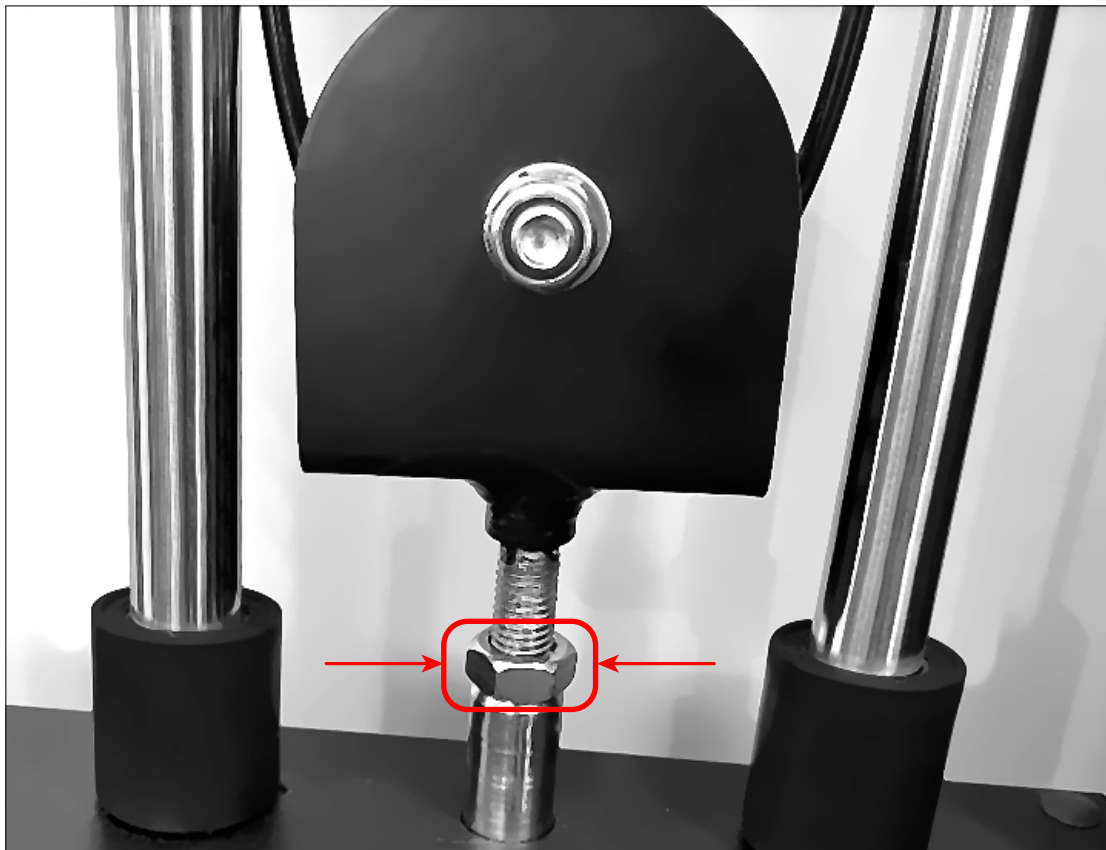

CLEAN GUIDE RODS

Step must be completed prior to installing. Failure to do so can leave residue from packaging and other sources stuck in the bushings. It causes buildup in the bushings of the top plates. They just need to be cleaned out as well as the guide rods.

Guide rods need to make sure they are cleaned prior to installation otherwise this will cause the top plate to get stuck. It causes buildup in the bushings of the top plates. They just need to be cleaned out as well as the guide rods.

Use Silicon Spray and fiber to remove any excess residue. These can be found around the house or at a nearby hardware store, pics below. Use silicon Spray and steel wool.

We use "B'laster 16-SL Industrial Strength Silicone Lubricant" and Steel Wool, Grade #0000 Super Fine Grade

